

6-Series

ELECTRIC WALKIE COUNTERBALANCED STACKER

SPECIFICATIONS

6BWC10 - 2000 lbs

6BWC15 - 3000 lbs

6BWC20 - 4000 lbs

Toyota's walkie counterbalanced stacker is a high performing, versatile, maneuverable and easy to use lift truck. It's the perfect solution for everyday material handling duties.

Standard Features

PERFORMANCE

- 2000 lbs capacity (6BWC10)
- 3000 lbs capacity (6BWC15)
- 4000 lbs capacity (6BWC20)
- 24 Volt electrical system
- MOSFET transistor control system
- Separately excited drive motor (SEM)
- UL-approved model type E
- On/off key switch
- Programmable performance
- Electronic raise and lower controls in operator handle
- Manual raise and lower controls
- Class 'H' motor insulation
- Oil-immersed power-train

BODY/EXTERIOR DESIGN

- Electronic horn
- 32.3"x13.3" battery compartment
- 30" wide ITA Class II fork carriage
- 42" fork length
- 48" load backrest extension

- Mast tilt, 3° forward / 8° backward
- Internal hose reeving
- Rubber drive tire, 10.5"x5"
- Polyurethane load wheels, 10"x4"
- Polyurethane caster wheels, 4"x2.5"
- Fully-hinged steel service access door
- Wide view 2-stage mast (V)
- Spring-loaded torsion bar suspension with automatic load-sensing adjustment and stabilizing casters
- Drive axle mounted string guards
- Pressure overload valve & lowering control fuses

OPERABILITY & ERGONOMICS

- Emergency power disconnect switch
- Automatic resetting circuit breaker
- Reverse polarity protection
- Mechanical drum brake
- Directional thumb control
- Direction reverse switch on control handle
- Control handle with 8.5° ergonomic angle
- Power on self test with self-diagnostics

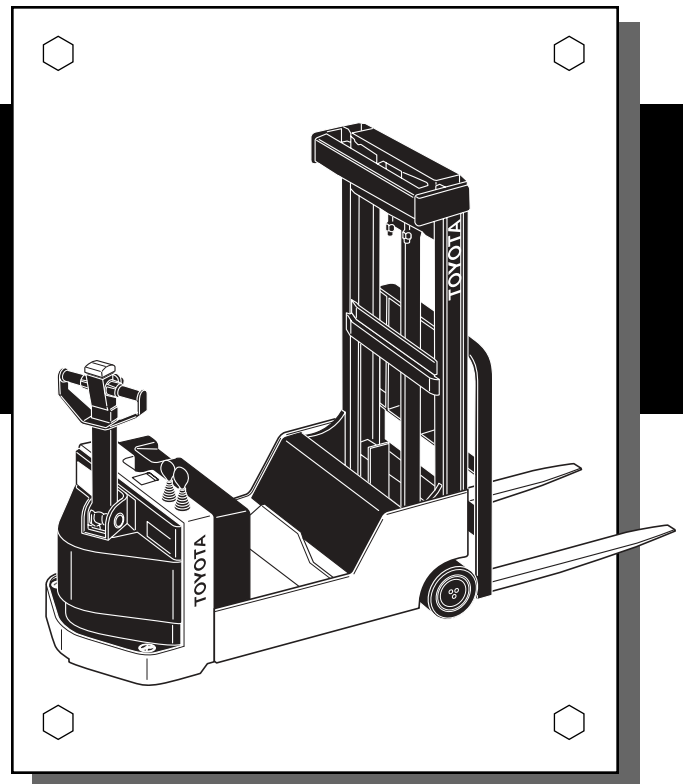

Optional Equipment

- Twist grip control handle in place of thumb control
- Hour meter
- Battery discharge indicator
- Combination battery discharge/ hour meter indicator
- Combination battery discharge/ hour meter indicator with lift interrupt
- UL-approved model type EE
- Corrosion conditioning
- Cold storage conditioning
- Audible travel alarm
- Battery compartment rollers
- Toggle switch in place of key switch
- Sideshifter
- 30", 36" or 48" fork lengths
- 36" or 44" load backrest extension
- Various drive tire compounds
- Various battery connectors
- Various strobe lights
- Various flashing beacons
- Wide view full free lift 2-stage mast (FV)
- Wide view full free lift 3-stage mast (FSV)

6BWC10.15.20 Specifications

Models	6BWC10	6BWC15	6BWC20
Load Capacity (with 24-in. load center)	2000	3000	4000
Brakes	Mechanical Drum Brake		

EXTERIOR DIMENSIONS

Carriage Width	in	30		
Basic Right Angle Stacking Aisle Width	in	See Chart		
A Maximum Fork Height (MFH)	in	128	124	
B Mast Lowered Height	in	83		
C Mast Extended Height	in	176	172	
D Free Lift	in	12	6	
E Wheelbase	in	47	52.3	58.6
F Head Length (Length to Fork Face) V mast	in	64.8	70.1	76.6
G Power Unit Width	in	34.1		
H Power Unit Height	in	32.5		
I Battery Roller Height	in	9.8		
J Tilt Range (Mast Tilt)	Fwd/Bwd	deg 3/8		
K Fork Size	TxWxL	in 1.5x4x42	1.75x4x42	
L Fork Adjustment	Min./Max.	in 8.5/30		
M Underclearance	in	3.6		
N Outside Turning Radius	in	56.7	62	68.3
O Load Distance	in	8.1		

DIMENSIONS OF BATTERY COMPARTMENT

P Battery Compartment LxW (open height)	in	32.3x13.3		
Total Weight	Without Battery	lb	3600	4800
Power Type			Battery	
Battery	Voltage/Capacity (6-hour ratings)	Max. V/AH	24/650	
	Weight	Min. lbs	950	
Electric Motors	Drive (60 min.)	hp	1.2	3.7
	Load Handling (5 min 20%)	hp	4.8	
Control Type	Drive		Transistor	
	Load Handling		Electromagnetic Contactor	

PERFORMANCE DATA

Maximum Travel Speed	full load	mph	2.9	3	2.8
	no load	mph	3.2	3.4	3.3
Lift Speed	full load	fpm	37	32	27
	no load	fpm	49		
Lowering Speed	full load	fpm	60		
	no load	fpm	44	42	
Gradeability ¹⁾	full load/no load	% (tan θ)	6/10		

1) Trucks are designed for level floor operation. Represents ability to transverse short ramps when required.

TIRES

Type (Drive/Caster/Load)	Rubber/Polyurethane/Polyurethane			
Size (dia. x width)	Drive	in	10.5x5	
	Caster	in	4x2.5	
	Load	in	10x4	

AISLE REQUIREMENTS - RIGHT ANGLE STACKING

6BWC10				6BWC15				6BWC20			
Pallet Width	Load Length			Pallet Width	Load Length			Pallet Width	Load Length		
	in	in	in		in	in	in		in	in	in
30	105	111		30	110	116		30	117	123	
40	104	111		40	110	116		40	116	122	
48	104	110		48	109	115		48	116	122	

Aisle width requirements are based on 6" clearance between each side of the load. Add a minimum of 6" to 10" for maneuverability. Add 2.5" when equipped with a side shifter.

DIMENSIONAL DRAWING 6BWC10.15.20

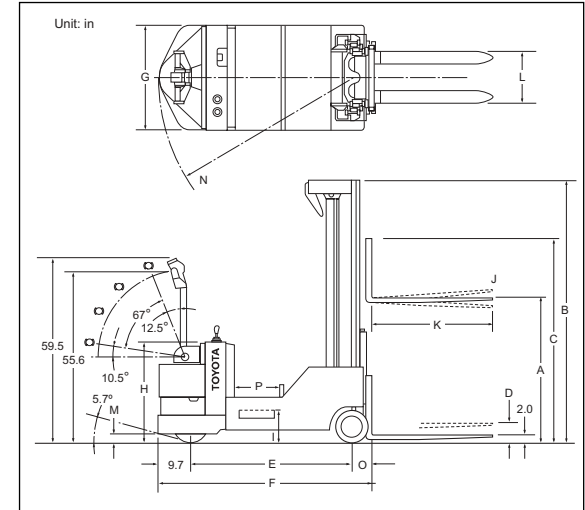

MAST SPECIFICATIONS & RATED CAPACITIES

6BWC10

Mast Type	Maximum Fork Height	Overall Lowered Height	Free Lift	Capacity @ 24 in LC
	in	in	in	lb
V	104	71	12	2000
	128	83	12	2000
	152	95	12	2000
FV	104	71	52	2000
	128	83	64	2000
	152	95	76	2000

Basic capacity is 2000 lbs at 24" load center. Actual capacity is dependent upon specific truck configuration. Minimum battery weight is 950 lbs. Reference Toyota's FL Manual for complete specifications.

6BWC15

Mast Type	Maximum Fork Height	Overall Lowered Height	Free Lift	Capacity @ 24 in LC
	in	in	in	lb
V	104	71	12	3000
	128	83	12	3000
	152	95	12	3000
FV	104	71	52	3000
	128	83	64	3000
	152	95	76	3000
FSV	150	71	53	3000
	180	83	65	3000
	189	87	69	3000

Basic capacity is 3000 lbs at 24" load center. Actual capacity is dependent upon specific truck configuration. Minimum battery weight is 950 lbs. Reference Toyota's FL Manual for complete specifications.

6BWC20

Mast Type	Maximum Fork Height	Overall Lowered Height	Free Lift	Capacity @ 24 in LC
	in	in	in	lb
V	100	71	6	4000
	124	83	6	4000
	150	95	6	4000
FSV	150	71	53	4000
	180	83	65	4000
	189	87	69	4000

Basic capacity is 4000 lbs at 24" load center. Actual capacity is dependent upon specific truck configuration. Minimum battery weight is 950 lbs. Reference Toyota's FL Manual for complete specifications.

Some product features described herein are optional. Please consult your dealer for specifications. Details of specifications and equipment are based on information available at time of printing and may change without notice.

00722-35193-802 8/02
Litho in U.S.A. (5M)

© 2002 Toyota Material Handling, U.S.A., Inc.
www.toyotaforklift.com

